



Instruction Manual

Karmel King - Digital

Export Model No. 2620DX, 2621DX, 2620DTX, 2621DTX



GOLD MEDAL[®] PRODUCTS CO.

10700 Medallion Drive, Cincinnati, Ohio 45241-4807 USA

SAFETY PRECAUTIONS

	⚠ DANGER
	<p>Machine must be properly grounded to prevent electrical shock to personnel. Failure to do so could result in serious injury, or death. DO NOT immerse any part of this equipment in water. DO NOT use excessive water when cleaning. Keep cord and plug off the ground and away from moisture. Always unplug the equipment before cleaning or servicing. Make sure all machine switches are in the OFF position before plugging the equipment into the receptacle.</p> <p>008_051514</p>

	⚠ DANGER
	<p>Improper installation, adjustment, alteration, service, or maintenance can cause property damage, injury, or death. Any alterations to this equipment will void the warranty and may cause a dangerous condition. This appliance is not intended to be operated by means of an external timer or separate remote-control system. NEVER make alterations to this equipment. Read the Installation, Operating, and Maintenance Instructions thoroughly before installing, servicing, or operating this equipment.</p> <p>014_020416</p>

	⚠ WARNING
	<p>To avoid burns, DO NOT touch the kettle or any heated surface. DO NOT place or leave objects in contact with heated surfaces.</p> <p>013_092414</p>

	⚠ WARNING
	<p>ALWAYS wear safety glasses when servicing this equipment.</p> <p>010_010914</p>

	⚠ WARNING
	<p>No user serviceable parts inside. Refer servicing to qualified service personnel.</p> <p>011_051514</p>

	⚠ WARNING
	<p>Read and understand operator's manual and all other safety instructions before using this equipment. To order copies of the operator's manual go to gmpopcorn.com or write to Gold Medal Products Co., 10700 Medallion Drive, Cincinnati, OH 45241 USA 1-(800)-543-0862</p> <p>022_060215</p>

SAFETY PRECAUTIONS (continued)

	⚠ WARNING
	DO NOT allow direct contact of this equipment by the public when used in food service locations. Only personnel trained and experienced in the equipment operation may operate this equipment. Carefully read all instructions before operation. 012_010914

	⚠ WARNING
	This machine is NOT to be operated by minors. 007_010914

This appliance is not intended for use by persons (including children) with reduced physical, sensory or mental capabilities, or lack of experience and knowledge, unless they have been given supervision or instruction concerning use of the appliance by a person responsible for their safety.

Note: Improvements are always being made to Gold Medal's equipment. This information may not be the latest available for your purposes. It is critical that you call Gold Medal's Technical Service Department at 1-800-543-0862 for any questions about your machine operations, replacement parts, or any service questions. (Gold Medal Products Co. does not assume any liability for injury due to careless handling and/or reckless operation of this equipment.) General images may be used in manual for reference only.

INSTALLATION INSTRUCTIONS

Inspection of Shipment

After unpacking, check thoroughly for any damage which may have occurred in transit. Claims should be filed immediately with the transportation company. The warranty does not cover damage that occurs in transit, or damage caused by abuse, or consequential damage due to the operation of this machine, since it is beyond our control (reference warranty in back of manual).

Manual

Read and understand the operator's manual and all other safety instructions before using this equipment. To order copies of the operator's manual go to gmpopcorn.com or write to Gold Medal Products Co., 10700 Medallion Drive, Cincinnati, OH 45241 USA 1-(800)-543-0862.

Model Description

The Digital Mark 20 Corn Treat Unit has a 20 gallon capacity and is available with either right hand or left hand dump capability (see below for unit description). For electrical specifications, refer to the Electrical Requirements section of this manual.

2620DX: Export Mark 20 with Digital Heat Control and Right Hand Dump.

2621DX: Export Mark 20 with Digital Heat Control and Left Hand Dump.

2620DTX: Export Mark 20 with Digital Heat Control, Right Hand Dump, and a Dual Timer.

2621DTX: Export Mark 20 with Digital Heat Control, Left Hand Dump, and a Dual Timer.

This appliance is intended to be used in household and similar applications such as staff kitchen areas in shops, offices and other working environments; farm houses; by clients in hotels, motels, bed and breakfast or other residential type environments.

Items Included with this Unit

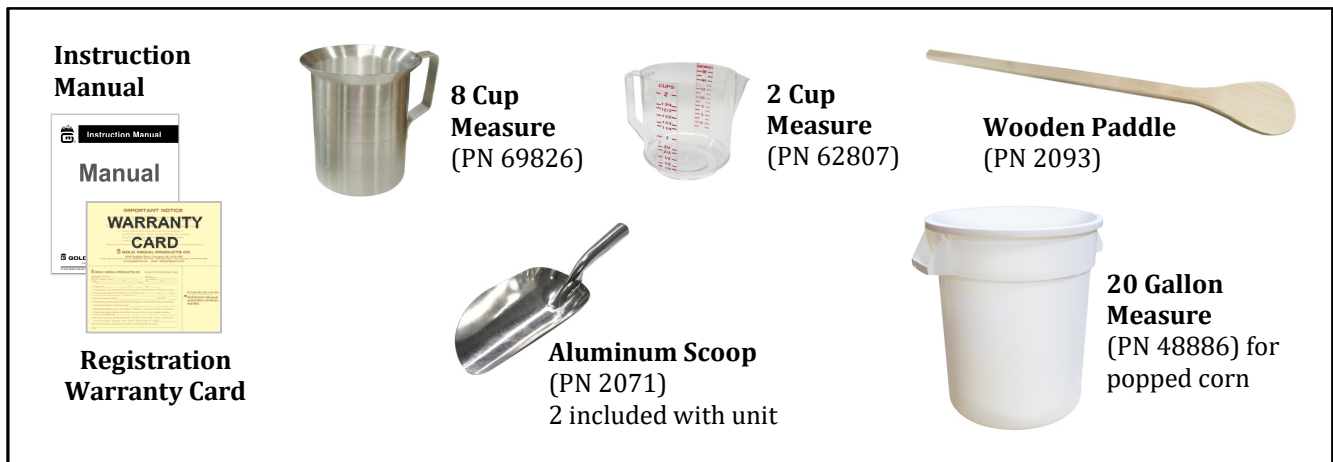

Setup

1. Remove all packaging and tape, and accessories before starting operation.
2. This unit must be properly fastened to a sturdy counter, see illustration below for counter mounting requirements.

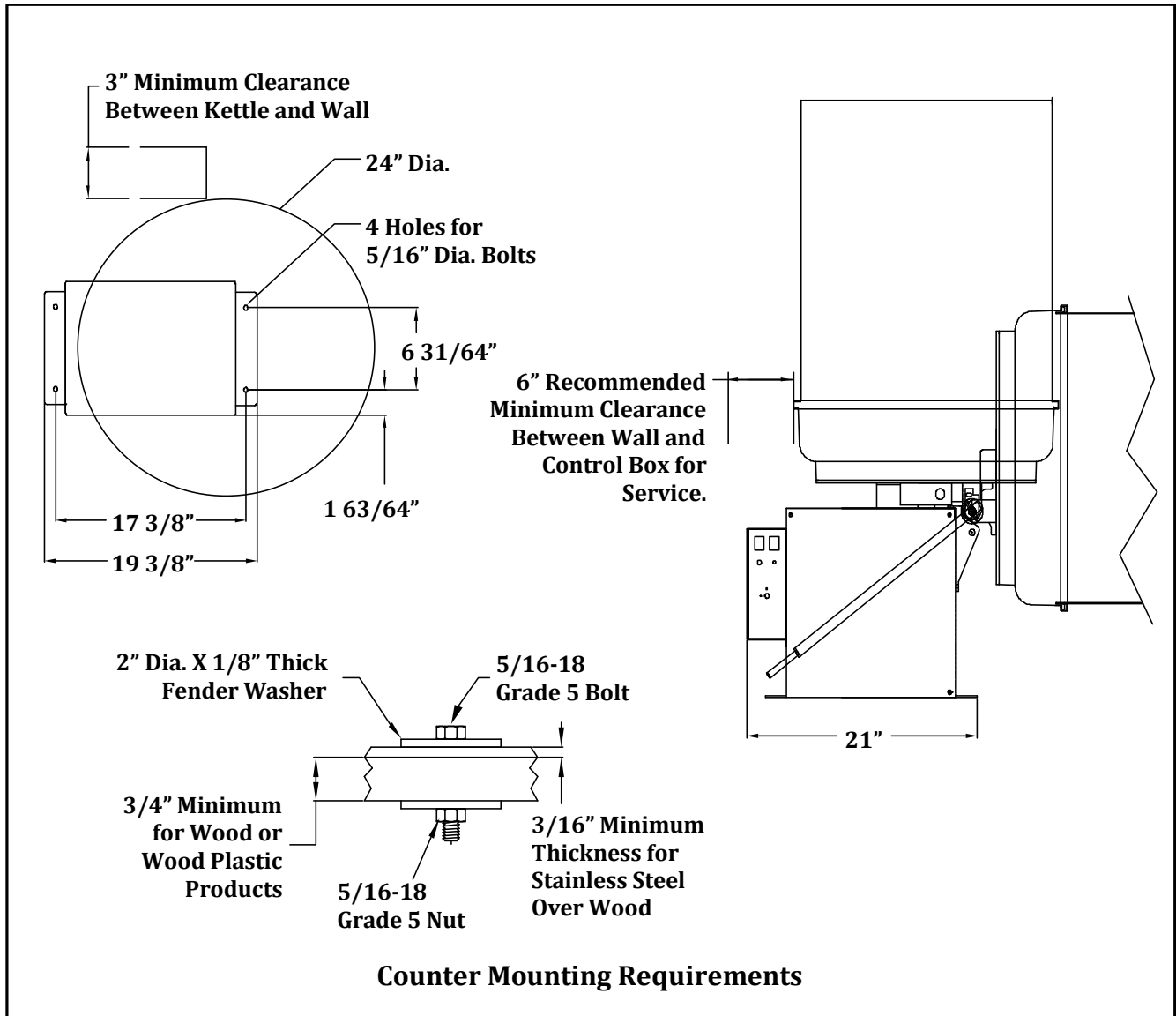

3. Prior to operation, rotate the top paddle from the shipping position into the mixing position and fix into place with the plunger provided. Pull knurled knob of plunger, to free plunger from shaft (see illustration below).

Once the paddle is positioned, make sure the plunger is securely set into the holes provided in the shaft.

4. After setup, the unit should be cleaned prior to use (see Care and Cleaning section of this manual).

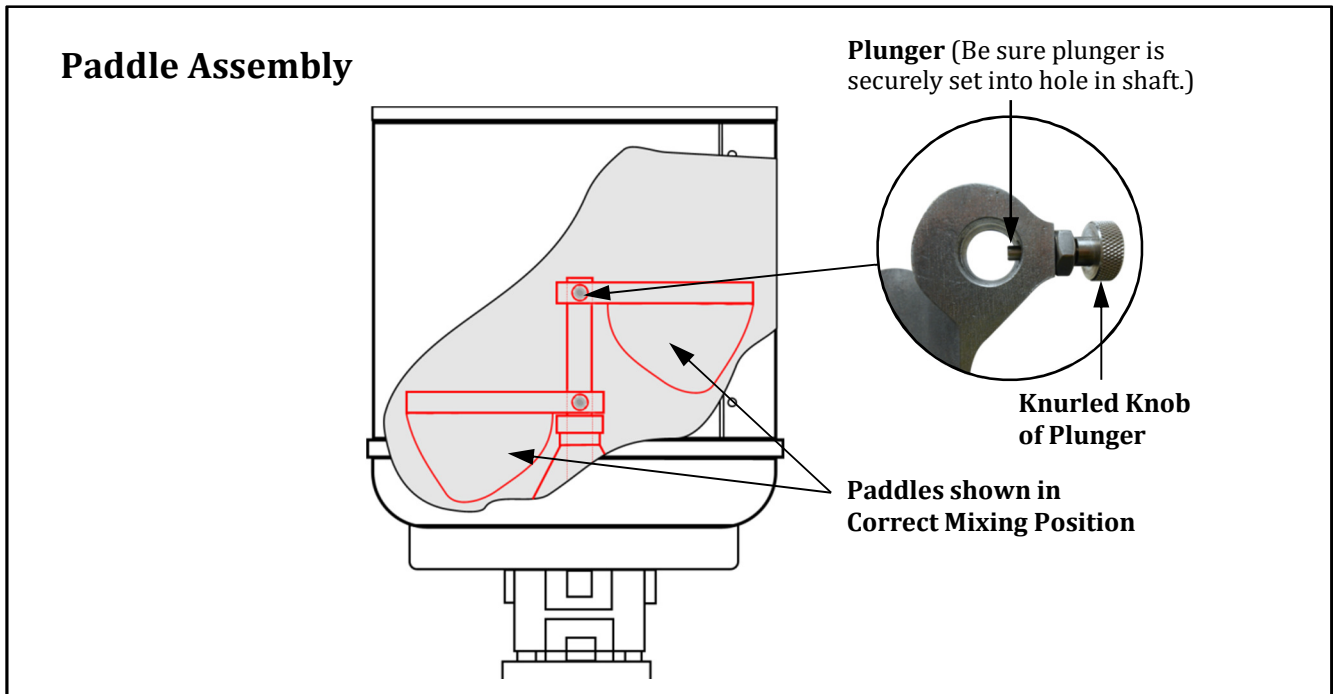

Electrical Requirements

The following power supply must be provided:

2620DX, 2620DTX and 2621DX, 2621DTX: 230/400 V~, 6076 W, 50 Hz

This unit is designed to operate on single phase, 16 AMP, 4 wire supply, 230 V~ (2 Hot, 1 Neutral, 1 Ground). All electrical components in this machine are 230 V (motors, heat elements, lights, etc.) and therefore require “Hot to Neutral” connection (**NOT** “Hot to Hot”).

	DANGER
	<p>Machine must be properly grounded to prevent electrical shock to personnel. Failure to do so could result in serious injury, or death. DO NOT immerse any part of this equipment in water. DO NOT use excessive water when cleaning. Keep cord and plug off the ground and away from moisture. Always unplug the equipment before cleaning or servicing. Make sure all machine switches are in the OFF position before plugging the equipment into the receptacle.</p> <p style="text-align: right; font-size: small;">008_051514</p>

A certified electrician must furnish sufficient power for proper machine operation and install any supplied receptacle. We recommend this equipment be on a dedicated and protected circuit. Failure to wire properly will void the warranty and may result in damage to the machine. It is Gold Medal Products Co.’s recommendation that this machine be plugged directly into a wall outlet. The use of extension cords is not recommended due to safety concerns, and may cause sacrificed and/or reduced performance. Make sure cord is located to prevent a trip hazard or unit upset.

Receptacle Wiring Diagram

A certified electrician must supply and install the required wall receptacle for this unit, follow the IMPORTANT instructions shown below.

This unit is designed to operate on single phase, 16 AMP, 4 wire supply. All electrical components in this machine are 230 V. If the receptacle is wired incorrectly, the heat elements/kettle and other electrical components could be at 400 V potential instead of the needed 230 V, resulting in excessive temperatures in the heat elements (i.e.: kettle) and possible fire, and/or damage to electrical components.

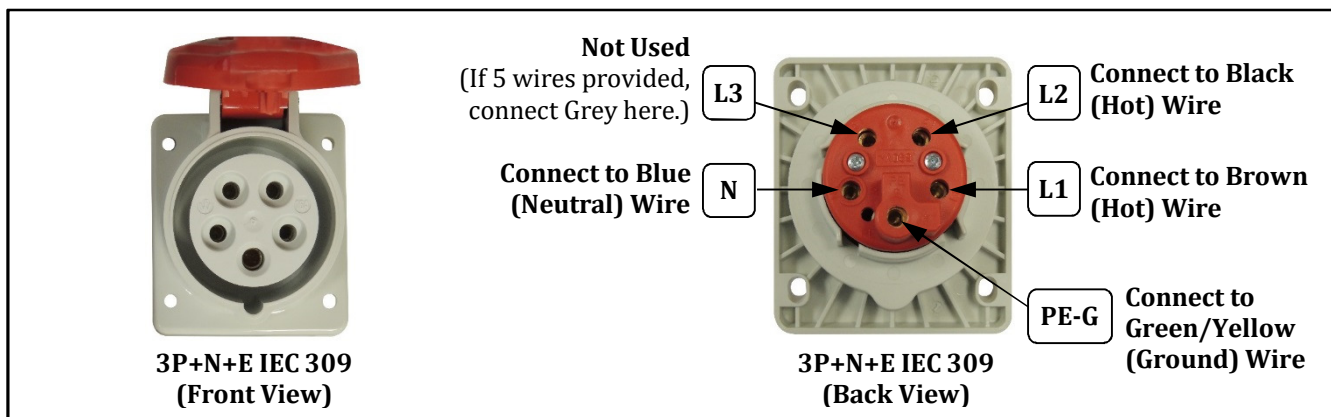



Before You Plug In Machine

1. Make sure all machine switches are OFF before plugging equipment into receptacle.
2. Make sure wall outlet can accept the grounded plugs (where applicable) on the power supply cord.
3. The wall outlet must have the proper polarity. If in doubt, have a competent electrician inspect the outlet and correct if necessary.
4. **DO NOT** use a grounded to un-grounded receptacle adapter (where applicable).
5. Install unit in a level position.



OPERATING INSTRUCTIONS

Controls and Their Functions

HEAT/MOTOR SWITCH

Two position, ON/OFF lighted rocker switch – provides power to the heating elements in the bottom of the kettle, and powers the agitator motor to turn for 30 seconds of every minute. The green switch light ON indicates there is power to these features.

Note: It is normal for the motor to stop for 30 seconds of every minute (when the Motor Only Switch is OFF).

MOTOR ONLY SWITCH

Two position, ON/OFF lighted rocker switch – provides power to the agitator motor to run continuously.

Note: The main function of this switch is for mixing the product/popcorn at the end of the cooking cycle with the kettle in the tilt position, and it is used for “cleaning mode”.

CIRCUIT BREAKER

The circuit Breaker protects the Motor and Heat Control from an overload condition.

KETTLE DUMP HANDLE

The Kettle Dump Handle tilts the kettle from the upright cook position to the mix position or the dump position. The 2 position bracket holds the handle in the tilted position.

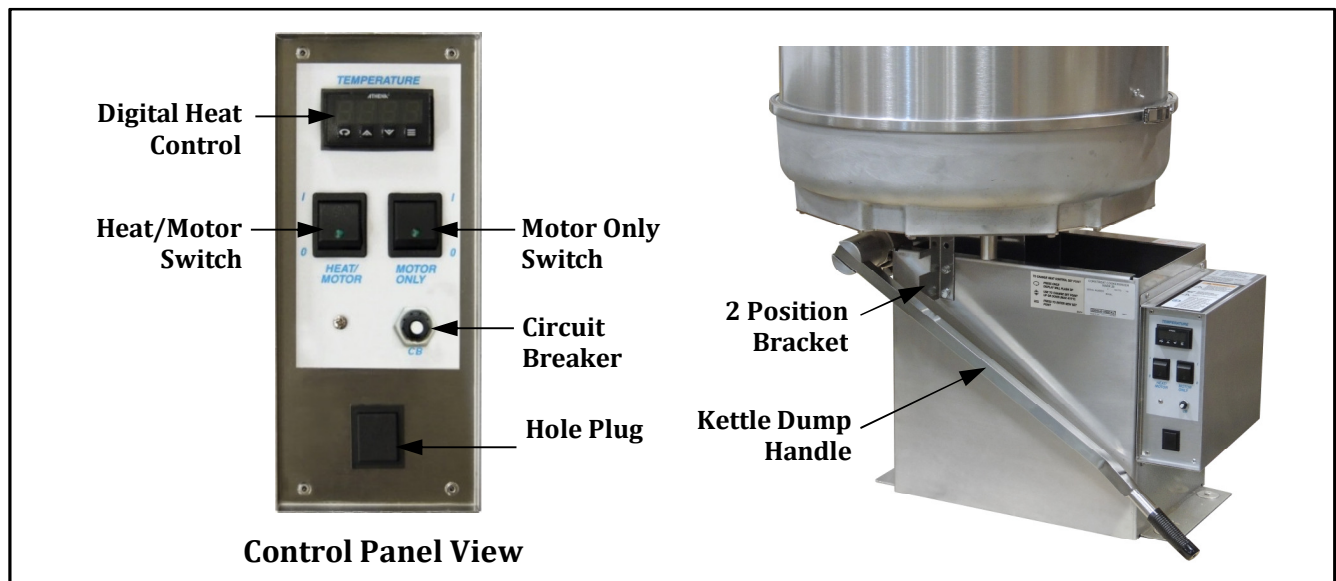





DIGITAL HEAT CONTROL

The Digital Heat Control adjusts the Set Point Temperature of the unit. The machine comes from the factory preset to achieve a Product Cook Temperature of 280°F. See Digital Heat Control Adjustment/Calibration section for adjusting the Product Cook Temperature.

D Models: The sound of the buzzer signals kettle heat shut-off. The buzzer will continue to sound until the unit is turned off or until the unit temperature falls below set point.

DT Models: Dual Timer units. The pre-alarm sounds the buzzer 40°F before Set Point Temperature; alerting operator that flavor can be added to the mix (the kettle will continue to heat the mixture). The second buzzer sounds kettle heat shutoff at a Product Cook Temperature of 280°F. Each buzzer only sounds for 10-15 seconds.

Buttons/Indicator Light Descriptions

UP Button / DOWN Button   – adjusts the Set point Temperature UP or DN when in programming mode.

Access Button  – accesses programming mode to change Set Point Temperature, see Heat Control Adjustment section.

Mode Button  – exits programming mode and locks in adjustments, see Digital Heat Control Adjustment section.

Digital Display – display shows temperature of the kettle; this is not the same as the product temperature. (Reference the Digital Heat Control Adjustment/Calibration section.)

Heat Indicator Light – light is ON when the unit is heating. See image below for D Model and DT Model indicator descriptions.

Buzzer Indicator Light – See image below for D Model and DT Model indicator light description.

Heat Indicator Light (D Models)

Light is ON when the unit is heating. It goes OFF when the buzzer sounds (signaling heat shut-off).



Buzzer Indicator Light (D Models)
Light comes ON when the buzzer sounds (signaling heat shut-off).

Digital Heat Control (D Models)

Heat Indicator Light (DT Models)

Light is ON when the unit is heating. It stays on until the **second** buzzer sounds (signaling heat shut-off).



Buzzer Indicator Light (DT Models)
Light is ON until the **first** buzzer sounds (pre-alarm), and then the light goes OFF.

Dual Timer Control (DT Models)

Digital Heat Control Adjustment/Calibration

Product Cook Temperature is the actual temperature of the PRODUCT (Caramel Corn Mix); this is measured with an accurate candy thermometer. Infrared temperature readers are NOT recommended.



Set Point Temperature is the temperature setting of the KETTLE; this is the temperature needed to get the Carmel Corn Mix up to the finished Product Cook Temperature of 280°F. The digital display shows the kettle temperature, NOT the product temperature.

Note: The Set Point Temperature will be higher than the product temperature. Refer to the candy thermometer for accurate product temperature.

Digital Heat Control Adjustment

The machine comes from the factory preset to achieve a **Product Cook Temperature** of 280°F. Small adjustments may need to be made for mix used or cooking conditions. If the product is ready, either before or after the buzzer sounds, then follow the steps listed to increase or decrease the **Set Point Temperature** of the kettle:

Note: D Models - The sound of the buzzer signals kettle heat shut-off.
DT Models - The sound of the second buzzer signals kettle heat shut-off.

1. To change the Set Point Temperature, press the  key. The display shows **SP** followed by a temperature number flashing. Use the arrow keys to set the desired temperature.
2. Once the temperature is set, press the  key to lock in the new temperature.

Digital Heat Control Calibration (Performed at the Factory)

This unit has been calibrated at the factory. Other than small adjustments made for mix used or cooking conditions (see above Digital Heat Control Adjustment), the unit is ready for use and should not need calibration.

To reset the Digital Heat Control back to factory settings follow the procedure shown below.

Note: For calibration purposes only, corn oil is used to determine the Digital Heat Control temperature setting which will produce an accurate finished product temperature of 280°F.

1. Start with a clean unit, which is cool before attempting to calibrate.
2. Fill the mixing bowl with a one inch depth of corn oil.
3. Turn the Heat/Motor Switch ON.
4. Use an accurate candy thermometer to measure the temperature of the oil in the mixing bowl. (Infrared temperature readers are NOT recommended.)



5. Set the digital control set point temperature to 400°F.
6. Turn the Motor Only Switch ON to stir the oil while it heats.
7. When the oil reaches 335°F, note the temperature displayed on the digital control and make that the Set Point Temperature.

**Note: The Set Point Temperature will be higher than the product temperature.
Refer to the candy thermometer for accurate product temperature.**

8. Allow oil to cool below 300°F, then repeat Step 5 to check the buzzer sounds at 335°F.
9. The unit is now calibrated for the heat control buzzer to sound at a finished product temperature of 280°F.

Caution: Allow hot oil to cool below 140°F before attempting to drain.



Making Carmel Corn

Instructions for Making Carmel Corn (Mark 20)

Always remember, leave the lid on the kettle during the first part of the batch. Once steam starts to “roll-up” from underneath the lid, then carefully remove lid for remainder of the cooking cycle.

CAUTION: Beware of rising steam; keep face and hands clear of rising steam.

1. Turn Heat/Motor Switch ON (DO NOT turn on the Motor Only Switch).
2. Add (4) 22 ounce packages of Gold Medal Carmel Corn Mix (Item No. 2094), 16 cups of granulated sugar (brown or white), and 32-48 ounces of water (add water last).

Note: When using Gold Medal “One Step” Carmel Corn Mix, **DO NOT** add granulated sugar.

3. Turn Motor Only Switch ON and mix for approximately one minute, then turn Motor Only Switch OFF. (With the Heat/Motor Switch ON, the motor will run for 30 seconds of every minute.)
4. Add 4 sticks (16 ounces) of coconut oil or vegetable oil. Put on the lid.

Note: Once steam starts to “roll-up” from underneath the lid, then carefully remove the lid for the remainder of the cooking cycle.

5. Allow mix to cook until the buzzer sounds at 280°F product temperature.

Dual Timer Units: When the first buzzer sounds, add flavor mixture (if desired), the unit will continue to heat until the second buzzer sounds at 280°F product temperature.

Note: Product temperature is measured with an accurate candy thermometer. (Reference the Heat Control Adjustment section.)

6. Turn Heat/Motor Switch OFF.
7. Turn Motor Only Switch ON.
8. Add 20 gallons of pre-popped corn.
9. Allow corn to mix for approximately 10 seconds with the kettle in the upright position.
10. Move kettle to the mix position and spray 20-30 “squirts” of GOLD Medal Free-N-Easy (Item No. 2250) for proper corn separation, and mix popcorn until thoroughly coated.
11. Dump the caramel corn into the cooling pan, and mix/separate the caramel corn using two popcorn scoops.
12. After dumping caramel corn, turn Motor Only Switch OFF.
13. Allow the finished product to cool before packaging.

During normal operation, sugar build-up will occur in the kettle. The build-up must be removed by steaming out the kettle every 3-4 batches, and especially before the machine is turned off for the day. If making single batches, with the unit turned off between batches, the kettle must be steamed out after each batch has been completed. Follow the Proper Kettle Cleaning Procedure in the Care and Cleaning section of this manual.

Care and Cleaning

	⚠ DANGER
	<p>Machine must be properly grounded to prevent electrical shock to personnel. DO NOT immerse in water. DO NOT clean appliance with a water jet. Always unplug the equipment before cleaning or servicing.</p> <p style="text-align: right;">025_111616</p>

	⚠ WARNING
	<p>To avoid serious burns, DO NOT touch the kettle while it is hot!</p> <p style="text-align: right;">028_020314</p>

Good sanitation practice demands that all food preparation equipment be cleaned regularly (only use non-toxic, food grade cleaners). A clean looking, well-kept machine is one of the best ways of advertising your product.

Corn Treat Cleaning Instructions

Note: It is extremely important to follow all of the cleaning procedures, otherwise parts damage and equipment failure will result. The warranty does not cover parts that are damaged due to improper cleaning.

Proper Kettle Cleaning Procedure

Follow the procedure below to steam the sugar build-up out of the kettle every 3-4 batches during regular operation and before the machine is turned off for the day. The kettle must also be steamed out after making single batches, if the machine is turned off between batches.

1. After all product has been removed, and the kettle has cooled for 15-20 minutes, carefully pour 24 oz. of water into the kettle.

CAUTION: Beware of rising steam; keep face and hands clear of rising steam.

2. Place the lid on the kettle, and turn the Heat/Motor Switch ON.
3. When water starts to boil, turn Heat/Motor Switch OFF.
4. Turn the Motor Only Switch ON; allow the machine to cool, then remove the lid and carefully pour the contents of the kettle into a pan or bucket. Steam the kettle twice to remove all traces of product.
5. Turn the Motor Only Switch OFF.
6. With all switches OFF, wipe out any excess sugar build-up from the kettle using a damp rag, then the kettle is ready to begin another batch.
7. Do not leave water in the pans overnight.



Daily Unit Cleaning Procedure

Follow the directions below to clean and sanitize the unit each day after use.

1. With the machine OFF, unplug the unit and allow it to cool before attempting to clean.
2. Make sure to clean all pans/accessories in order to sanitize them before each use.
3. Release the draw latch to easily remove the mixing drum, then remove paddles. The mixing drum and paddles can be taken to the sink to clean.
4. Wipe the kettle lead cord with a clean **SLIGHTLY** damp cloth. **DO NOT get moisture into the kettle lead-in cord, severe damage will result.**
5. The cabinet of your machine should be wiped clean daily (or more, depending on usage) with a clean soft cloth, **SLIGHTLY** dampened with soap and hot water.
6. Wipe the stainless steel parts with a clean cloth and cleaner designed for stainless steel, such as Gold Medal Watchdog Stainless Cleaner (Item No. 2088).
DO NOT use oven cleaners or abrasive materials as they will damage parts of the machine.

Proper Hub Seal Assembly Cleaning Procedure

Follow the steps below weekly to ensure proper machine performance:

Important: For proper machine performance, keep the hub seal and o-rings clean.

1. With the machine OFF, unplug the unit from the power source and allow it to cool before attempting to clean the Hub Seal Assembly.
2. Pull knurled knob of plunger, and lift off mix paddles.
3. Remove any burrs on the shaft using a fine grit emery paper to lightly sand the surface. If the burrs are not removed, damage may occur to the o-ring/oil seal during removal/installation.
4. Remove the hub seal assembly and soak it in hot water to clean.
5. Clean the area around the center hub. Remove any product residue. (See Kettle Shaft Maintenance section for note on lubricating kettle bushings.)
6. Lightly lubricate the center hub of the kettle with a small amount of vegetable oil to allow for easy re-installation of the hub seal assembly.
7. Slide the clean hub seal assembly down the agitator shaft. Apply pressure to ease the assembly over the center hub of the kettle until it seats properly.
8. After the hub seal assembly has been properly installed, re-install the mix paddles onto the agitator shaft.

Note: Make sure the plunger of each paddle is securely set into the holes provided in the shaft.



Hub Seal and Paddle Assembly

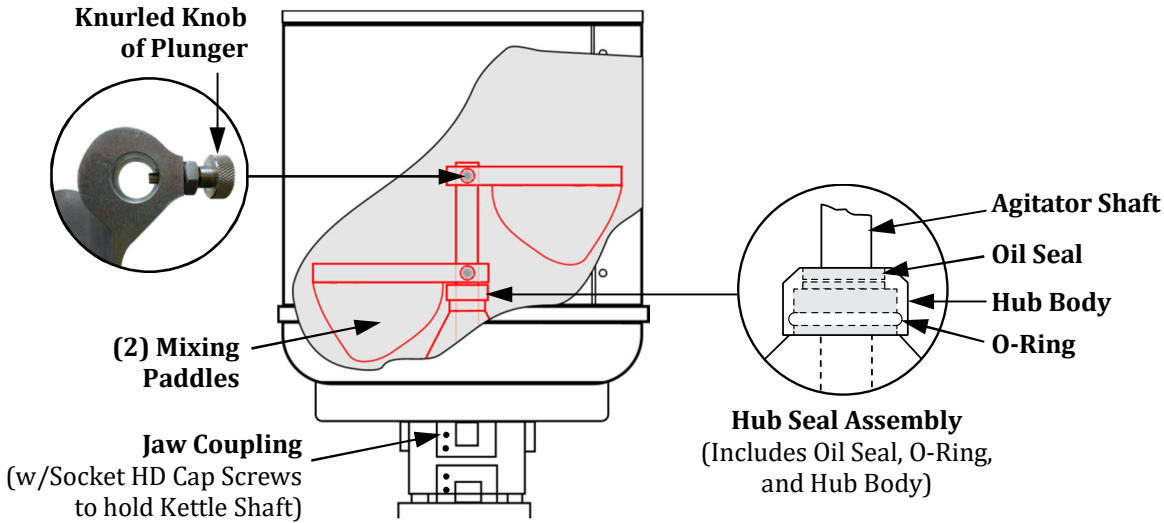



Troubleshooting



Issue	Possible Cause	Solution
Kettle Does Not Heat	<p>A. Power to Unit</p> <p>B. Circuit Breaker</p> <p>C. Kettle Heat/Motor Switch</p> <p>D. Control</p>	<p>A. Make sure the unit lead-in cord is plugged in.</p> <p>B. Check the condition of the circuit breaker. The breaker may trip during transit, if reset and trips again, contact qualified service personnel for inspection/repair before going any further.</p> <p>C. Have qualified service personnel check the voltage to and from the Heat/Motor Switch; if switch is defective, replace it.</p> <p>D. A defective RTD lead will cause the kettle not to heat. Have qualified service personnel check for good connections from the kettle to the control.</p>
Indicator Lights ON or OFF at incorrect time.	<p>A. Control Indicator Lights (Reference Controls and Their Functions section for indicator light descriptions.)</p>	<p>A. D Models - The Heat Indicator Light and the Buzzer Indicator Light should NOT be on at the same time. Contact qualified service personnel for inspection/repair.</p> <p>DT Models - If the Buzzer Indicator Light goes out and the pre-alarm is not sounding, contact qualified service personnel for inspection/repair.</p>
Error Code on Digital Display	<p>A. Digital display error code Err.H or Err.L</p>	<p>A. Have qualified service personnel check the RTD resistance value (should read approx. 110 ohms at room temperature); also check for shorts or opens.</p> <p>If RTD resistance value is OK and there are no shorts or opens, then replace digital temperature control.</p>
Kettle Agitator Does Not Turn	<p>A. Kettle Agitator Shaft/Motor Shaft</p>	<p>A. If the kettle agitator shaft is not rotating, DO NOT use. Have qualified service personnel inspect/repair as needed.</p>
Long Cooking Cycles	<p>A. Heating Element</p> <p>B. Low Voltage</p>	<p>A. One of the heating elements in the kettle may be burned out. This would result in the kettle never reaching the proper operating temperature. Contact qualified service personnel for inspection/repair.</p> <p>B. Unit is designed to make approximately 3 batches per hour when operated at full voltage. To get unit warmed up, the first batch usually takes about 5 minutes longer. If machine is operated on low voltage, the kettle will not reach the proper operating temperature causing longer cooking cycles.</p> <p>230 V units need a 218 V minimum.</p>





Long Cooking Cycles (continued)	C. Inadequate Supply Lines	C. Inadequately sized electrical supply lines, in addition to being a fire hazard, would also prevent the kettle from reaching the proper operating temperature. Check with a qualified electrician.
--	----------------------------	--





MAINTENANCE INSTRUCTIONS

	 DANGER
	<p>Machine must be properly grounded to prevent electrical shock to personnel. Failure to do so could result in serious injury, or death. DO NOT immerse any part of this equipment in water. DO NOT use excessive water when cleaning. Keep cord and plug off the ground and away from moisture. Always unplug the equipment before cleaning or servicing. Make sure all machine switches are in the OFF position before plugging the equipment into the receptacle.</p> <p>008_051514</p>

	 DANGER
	<p>Improper installation, adjustment, alteration, service, or maintenance can cause property damage, injury, or death. Any alterations to this equipment will void the warranty and may cause a dangerous condition. This appliance is not intended to be operated by means of an external timer or separate remote-control system. NEVER make alterations to this equipment. Read the Installation, Operating, and Maintenance Instructions thoroughly before installing, servicing, or operating this equipment.</p> <p>014_020416</p>

	 WARNING
	<p>No user serviceable parts inside. Refer servicing to qualified service personnel.</p> <p>011_051514</p>

	 CAUTION
	<p>THE FOLLOWING SECTIONS OF THIS MANUAL ARE INTENDED ONLY FOR QUALIFIED SERVICE PERSONNEL WHO ARE FAMILIAR WITH ELECTRICAL EQUIPMENT. THESE ARE NOT INTENDED FOR THE OPERATOR.</p> <p>027_010914</p>

New Paddle/Hub Seal Kit Installation Kettle Shaft Maintenance

1. With the machine OFF, unplug unit from the power source and allow it to cool.
2. Pull knurled knob of plunger, and lift off mix paddles.
3. Remove the old hub seal assembly.
4. Remove any burrs on the shaft using a fine grit emery paper to lightly sand the surface. If the burrs are not removed, damage may occur to the new o-ring/oil seal during installation.
5. Clean the area around the center hub. Remove any product residue.

Note: The kettle shaft should be removed monthly and the bushings lubricated with Never Seez® (use White Food Grade **ONLY**). To do this, loosen the (2) socket head cap screws in the jaw coupling and remove the shaft. **DO NOT lose the shaft key; this must be reset into place when reassembling.**

6. Lightly lubricate the center hub of the kettle with a small amount of vegetable oil to allow for easy installation of the hub seal assembly.
7. Slide the new hub seal assembly down the agitator shaft. Apply pressure to ease the assembly over the center hub of the kettle until it seats properly (see image below).
8. After the hub seal assembly has been properly installed, re-install the mix paddles onto the agitator shaft.

Note: Be sure the plunger of each paddle is securely set into the holes provided.

9. Rotate shaft by hand to ensure paddle does not touch the kettle bottom; re-adjust shaft if needed.

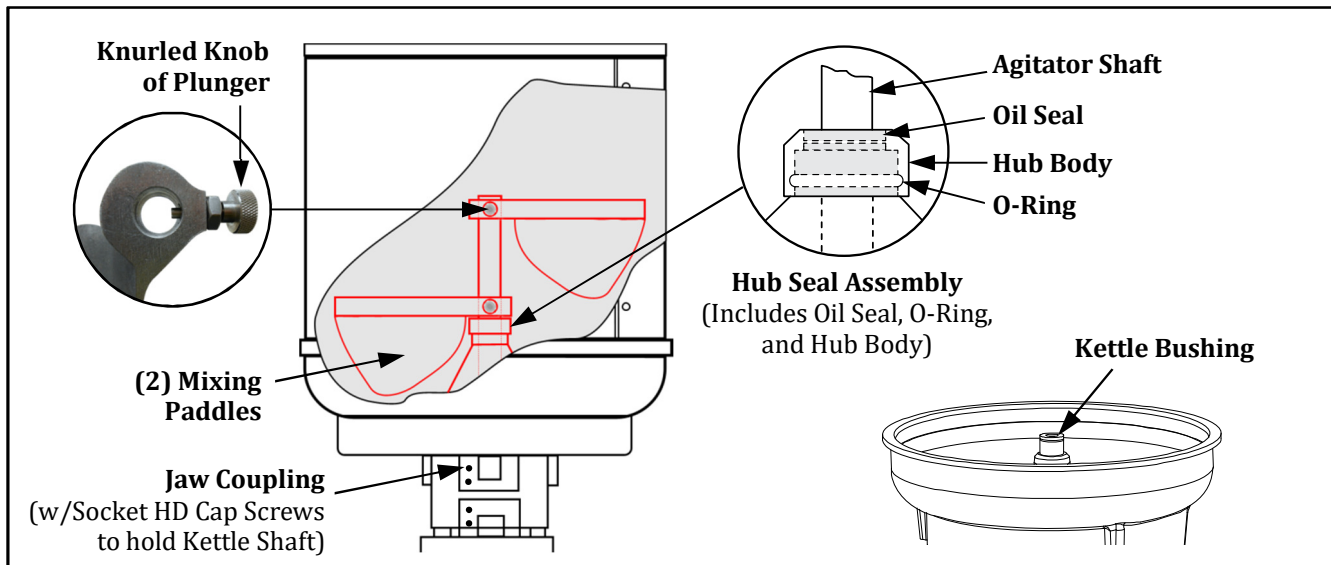



ORDERING SPARE PARTS

1. Identify the needed part by checking it against the photos, illustrations, and/or parts list. (General images may be used in manual for reference only.)
2. Use only approved replacement parts when servicing this unit.
3. When ordering, please include part number, part name, and quantity needed.
4. Please include your model number, serial number, and date of manufacture (located on the machine nameplate/data plate) with your order.
5. Address all parts orders to:

Parts Department
Gold Medal Products Co.
10700 Medallion Drive
Cincinnati, Ohio 45241-4807

Or, place orders by phone or online:

Phone: (800) 543-0862
(513) 769-7676
Fax: (800) 542-1496
(513) 769-8500
E-mail: info@gmpopcorn.com
Web Page: gmpopcorn.com

Cabinet Exterior



Item	Parts Description	Part Number
		All Models
1	LID ASSEMBLY	48827
2	2 POSITION BRACKET	46153
3	1/4-20 X 3/4 GRADE 5 BOLT	74520
4	1/4-20 SERRATED LOCK NUT	46311
5	CONTROL BOX COVER	55453
6	8-32 X 1/4 PHIL PAN M/S	87314

Cabinet Exterior/Spring Assembly – Parts Breakdown

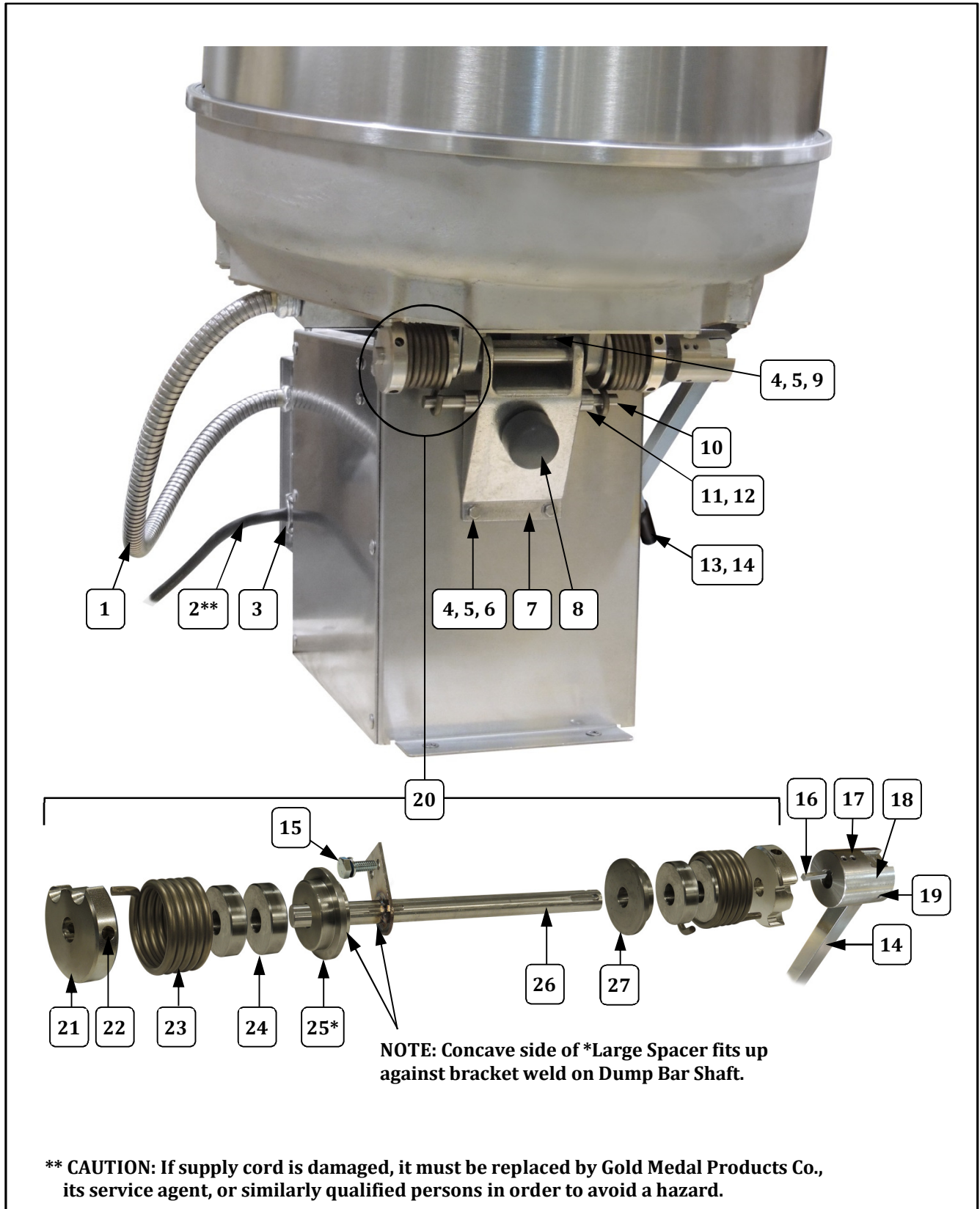



Cabinet Exterior/Spring Assembly – Parts List

Item	Parts Description	Part Number	
		RH Models 2620DX, 2620DTX	LH Models 2621DX, 2621DTX
1	KETTLE LEAD IN ASSY (includes connectors)	69867	69867
2**	LEAD-IN CORD ASSY. EXPORT	82943	82943
3	STRAIN RELIEF T&B 3304	82227	82227
4	1/4-20 X 3/4 HEX CAP 18-8	12515	12515
5	FLAT WASHER 1/4 STAINLESS	87261	87261
6	1/4-20 SERRATED LOCK NUT (top side of bracket use a 1/4-20 ESLOK Hex Nut)	46311	46311
7	KETTLE MTNG BRKT MACHINED	48812	48812
8	KETTLE STOP	70047	70047
9	HEX NUT 1/4-20 ESLOK	42361	42361
10	SPRING RETAINER ROD	82551	82551
11	SET COLLAR 1/2ID X 7/8OD	47326	47326
12	SET SCREW 1/4-20 X 3/16	47751	47751
13	GRIP, HANDLE BAR	46028	46028
14	TILT LEVER, MARK 10 CTC	46488	46488
15	1/4-20 X 3/4 GRADE 5 BOLT	74520	74520
16	KEY (.187 X .187 X 3/4)	12509	12509
17	SET SCREW 1/4-20 X 3/8	74125	74125
18	HUB	48839	48839
19	COILED SPRING PIN	48883	48883
20	RT SPRING & DUMP BAR ASSEMBLY (includes items listed below)	48842	
	LT SPRING & DUMP BAR ASSEMBLY (includes items listed below)		48882
21	COLLAR	74661	74661
22	SET SCREW, 5/16-18 X 5/8 (3 req'd. per collar)	74662	74662
23	TORSION SPRING	74660	74660
24	SPACER	74658	74658
25*	SPACER,LARGE (DUMP SIDE) - Concave side fits up against bracket weld on Dump Bar Shaft	74659	74659
26	RT DUMP BAR WELDMENT	48841	
	LEFT DUMP SHAFT WELDMENT		48881
27	SPACER,LARGE (CUSTOMER SIDE)	74690	74690

Kettle and Drum – Parts Breakdown

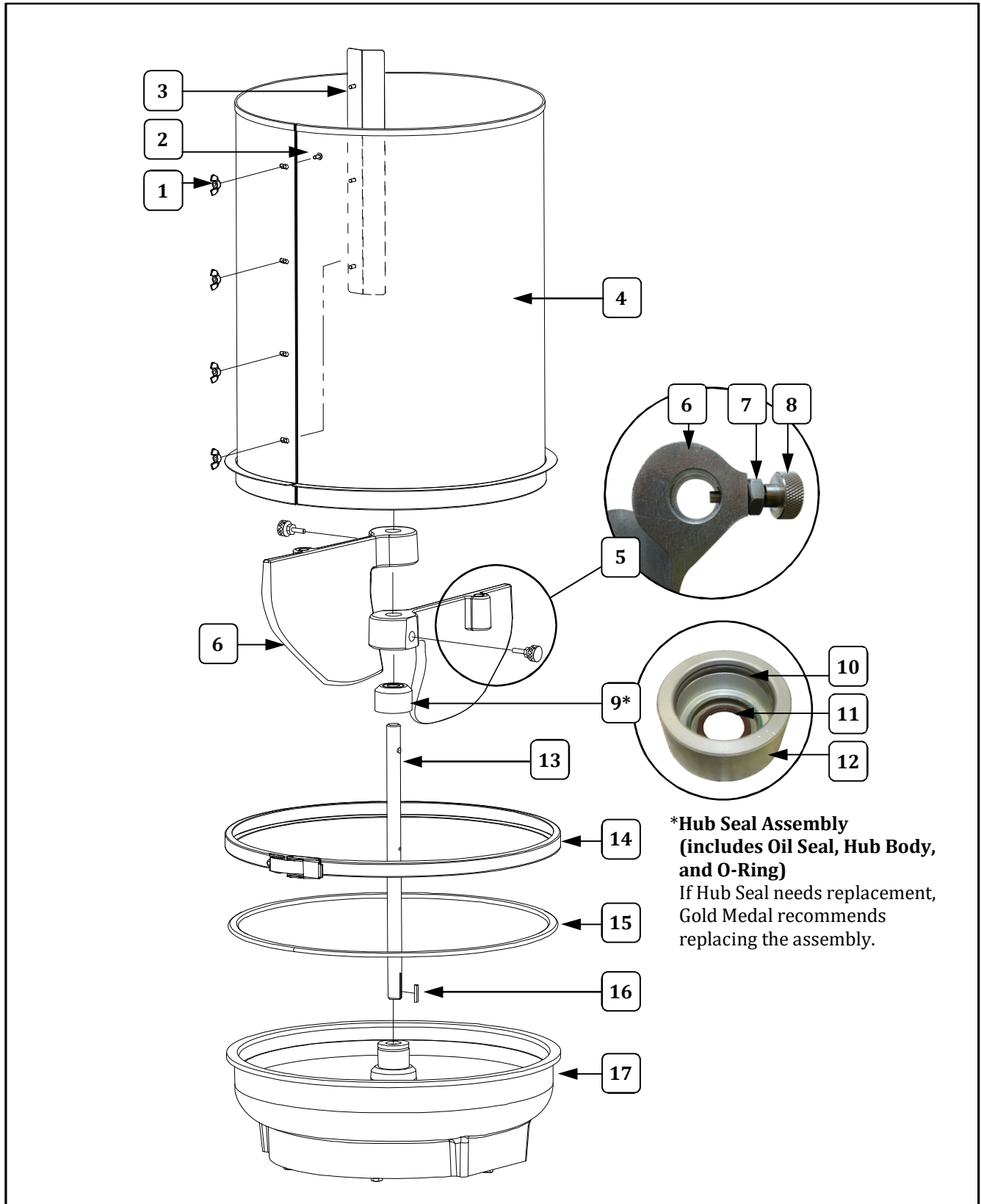



Kettle and Drum – Parts List

Item	Parts Description	Part Number
		All Models
1	WING NUT, #8-32	89126
2	8-32 X 3/8 PAN HD PH M/S	12389
3	BLENDING STRIP	46702
4	MIXING DRUM	48819
5	MIXER PADDLE ASSY (includes Mix Paddle, Hex Nut and Plunger)	111408
6	MIXER PADDLE MACHINED	111407
7	HEX NUT 5/8-11	111402
8	PLUNGER 5/8-11	111401
9	HUB SEAL ASSY MARK 10,20 (includes Oil Seal, Hub Body, and O-Ring)	46646
10	O-RING 1 3/4ID X 2OD	46641
11	HUB SEAL (If Hub Seal needs replacement, Gold Medal recommends replacing the assembly.)	46640
12	HUB SEAL BODY	46642
13	DRIVE SHAFT	111406
14	RETAIN RING MARK 20	48820
15	DRUM SEAL MARK 20	48822
16	KEY (.187 X .187 X 3/4)	12509
17	KETTLE ASSY, ELECTRONIC (includes Shaft, Hub Seal Assy, Retaining Ring and Gasket; also see Kettle Bottom and Kettle Element View sections for itemized parts breakdown).	48828EX

Kettle Bottom Plate/Motor Mount – Parts Breakdown

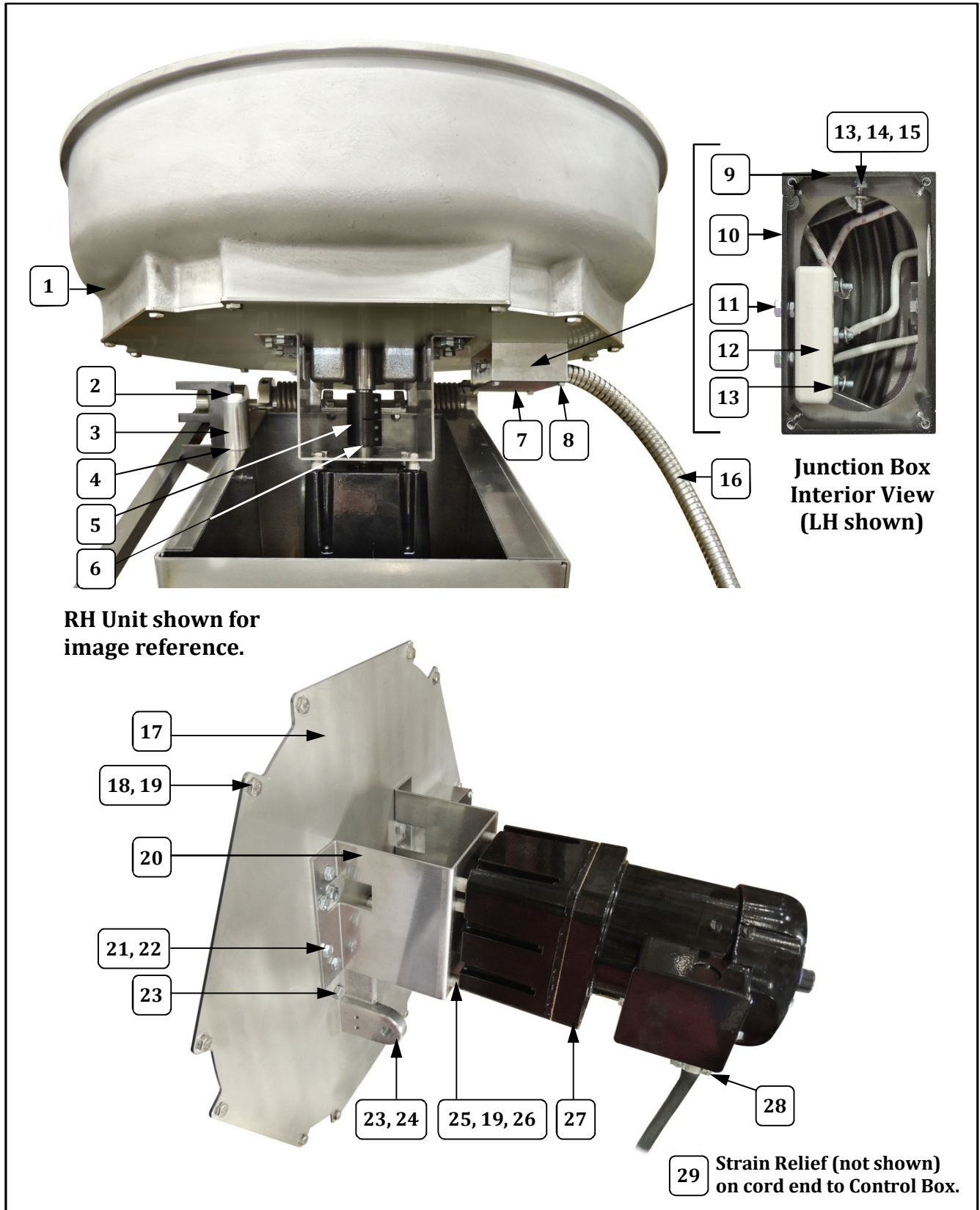



Kettle Bottom Plate/Motor Mount – Parts Breakdown

Item	Parts Description	Part Number
		All Models
1	KETTLE ASSY, ELECTRONIC (see Kettle Bottom and Kettle Element View sections for itemized parts breakdown)	48828EX
2	KETTLE REST BUMPER (rubber bumper)	83111
3	KETTLE REST (metal rest/holds rubber bumper)	83110
4	1/4-20 X 3/4 GRADE 5 BOLT	74520
5	DRIVE COUPLING	48826
6	.187 X .187 X 3/4 KEY	12509
7	JUNCTION BOX COVER	83262
8	8-32 X 1/2 SLOTTED H W H (screws for cover)	49379
9	JUNCTION BOX LEAD-SIDE	68875
10	JUNCTION BOX TERMINAL-SIDE	83261
11	8-32 SERRATED FLANGE NUT	61151
12	TERMINAL BLOCK KETTLE	41129
13	8-32 HEX M/S NUT	74149
14	8-32 X 3/4 PHIL PAN MS SS	39007
15	WASHER #8 INTERNAL TOOTH	74150
16	KETTLE LEAD IN ASSY (includes connectors)	69867
17	BOTTOM PLATE	48817
18	1/4-20 X 1/2 HX HD SCREW	12382
19	WASHER 1/4 INTERNAL TOOTH	12383
20	MOTOR MOUNT (Bracket)	48818
21	5/16-18 X 1/2 HHC GRADE 2	47206
22	5/16-18 SERRATED LOCK NUT	49317
23	HEX BOLT 3/8-16 X 3/4	20051
24	PIVOT CASTING MACHINED	48810
25	1/4-20 X 1 HX HD C S 18-8 (fastens motor)	12185
26	MOTOR SPACER	67207
27	1/4 HP DRIVE MOTOR (includes shaft key)	48880
28	STRAIN RELIEF T&B 3302 (Metal strain relief)	89045
29	STRAIN RELIEF (Plastic Strain Relief on cord end to Control Box)	67060

Kettle Element View - Parts Breakdown

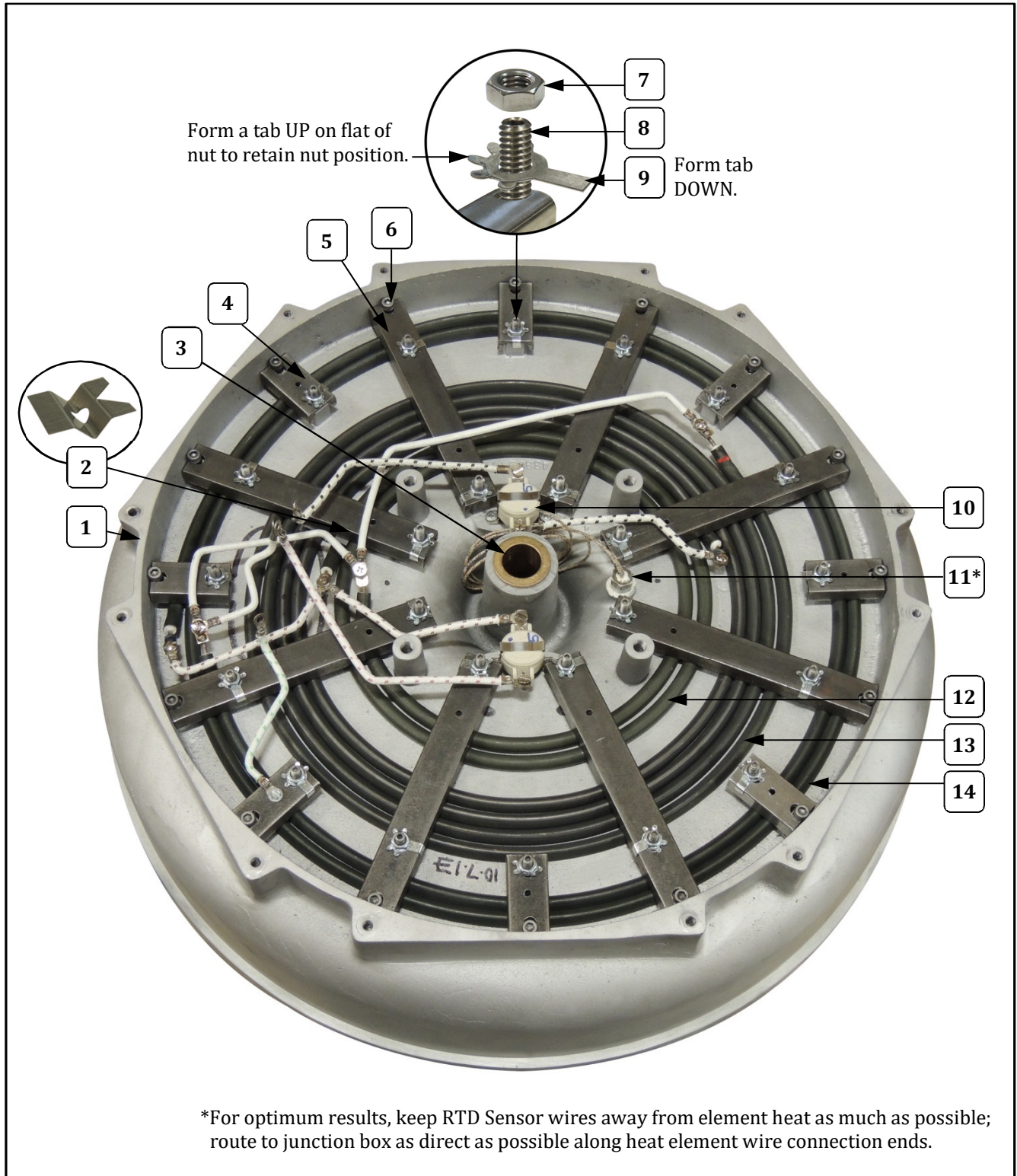



Kettle Element View - Parts Breakdown

Item	Part Description	Part Number
		All Models
1	KETTLE, CORN TREAT CENTER (includes 2 of Item 3 below, top and bottom bushings)	48829
2	ELEMENT SHIM	68787
3	BUSHING, MIX BOWL (2 Required, one used on top and one on bottom)	46484
4	ELEMENT CLAMP - Short (8 required)	48832
5	ELEMENT CLAMP - Long (8 required)	48831
6	1/4-20 X 1/2 SHCS	46722
7	HEX NUT 1/4-20	74133
8	1/4-20 x 1.25 SET SCREW	69140
9	NUT RETAINER	50190
10	THERMOSTAT KETTLE L-510	82219
11	RTD HEAT SENSOR	46299
12	TUBULAR ELEMENT, 1500W	48800EX
13	2700W 240V HEAT ELEMENT	46498
14	2100 WATT 240V HEAT ELEMENT	48887

Digital Control Panel – Parts Breakdown

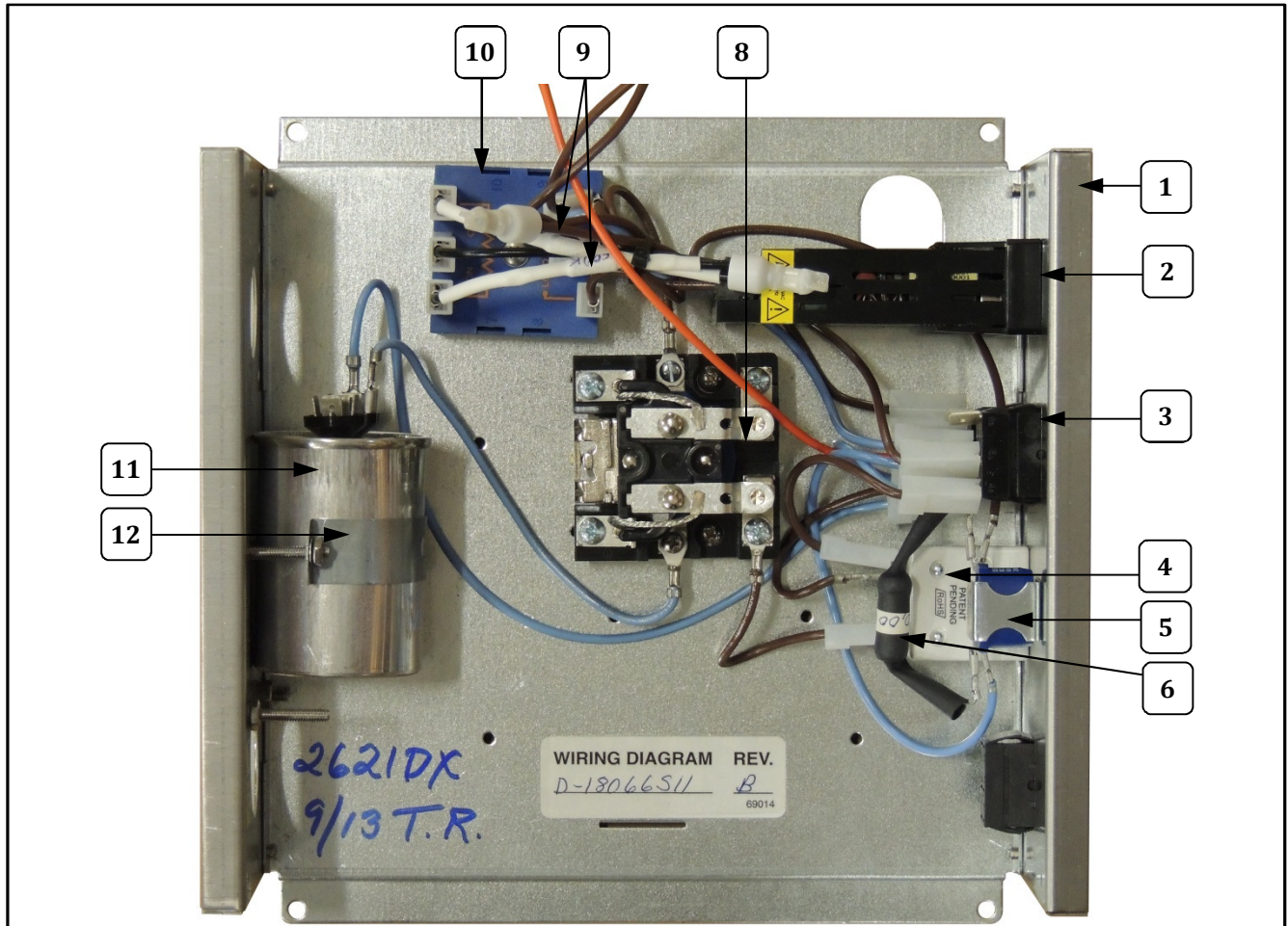

**Digital Control Panel Interior View
(Model 2621DX Shown)**

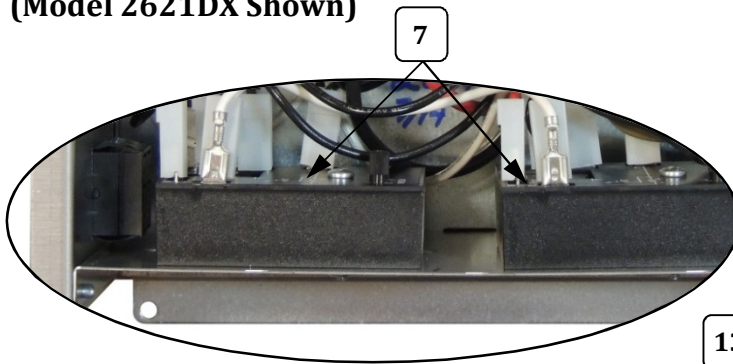

Dual Timers (on DTX Models only)

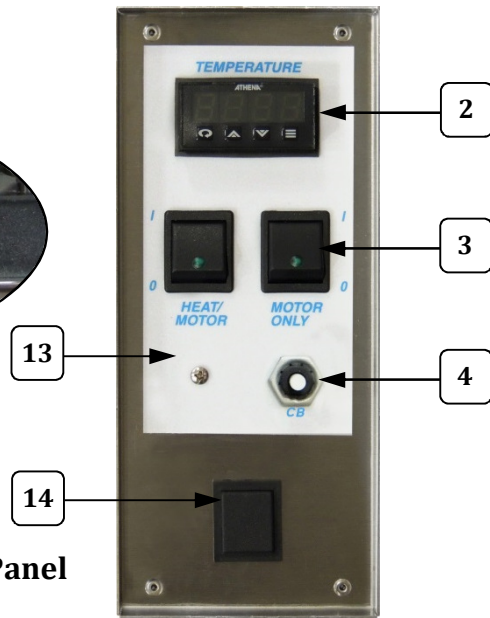

**Digital Control Panel
Exterior View**

Digital Control Panel – Parts List

Item	Parts Description	Part Number			
		2620DX	2621DX	2620DTX	2621DTX
1	CONTROL BOX ASSY (includes support and cover)	48681		48681	
2	TEMPERATURE CONTROL 32C	48720	48720	48720	48720
3	SWITCH, ROCKER DPDT LGHT	48616	48616	48616	48616
4	CIRCUIT BREAKER, 10A 277V	48659	48659	48659	48659
5	BUZZER SIGNAL 240 VAC	46120	46120	46120	46120
6	RESISTOR, 10K 8 WATT	48612EX	48612EX	48612EX	48612EX
7	TIMER, ONE SHOT OFF TRIG (2 required)			55464EX	55464EX
8	RELAY, 30A DPST 240V	55219EX	55219EX	55219EX	55219EX
9	RESISTOR, 500K 1 WATT (2 required)	55009	55009	55009	55009
10	TIMER, PERCENTAGE 60 SEC	48688EX	48688EX	48688EX	48688EX
11	20 MFD CAPACITOR	55558	55558	55558	55558
12	CAPACITOR STRAP	48301	48301	48301	48301
13	NAMEPLATE	48668	48668	48668	48668
14	HOLE PLUG, ROCKER SWITCH	42743	42743	42743	42743

Safety Labels



1



2



4

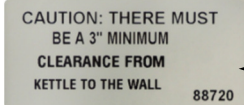

3



5

Unit Labels

Power Cord Label

Item	Part Description	Part Number
		All Models
1	COOKER LABEL	111031
2	CAUTION HOT LABEL	38201
3	MINIMUM CLEARANCE LABEL	88720
4	MAIN GROUND LABEL	42375
5	WARNING LABEL CORD	68720

Accessories

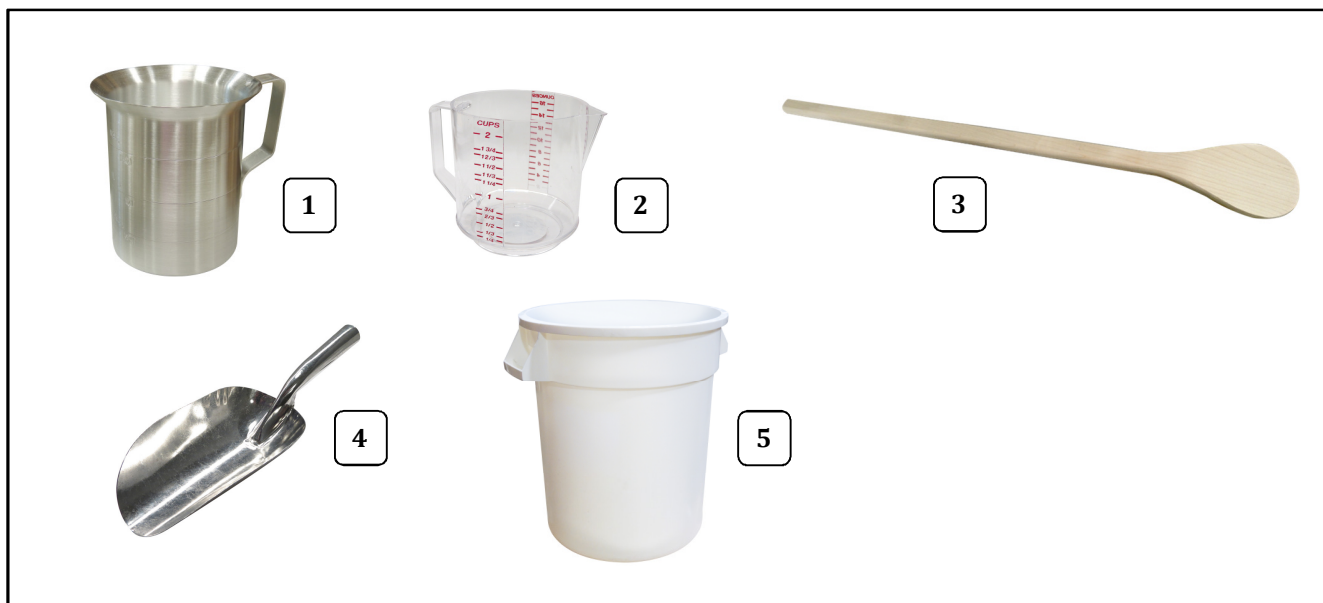

Item	Part Description	Part Number
		All Models
1	8 CUP MEASURE	69826
2	2 CUP ACRYLIC MEASURE	62807
3	36IN WOODEN MIXING PADDLE	2093
4	STAMPED ALUM SCOOP	2071
5	CORN MEASURE (20 Gallon)	48886



WARRANTY

Gold Medal Products Co. warrants to the original purchaser each item of its manufacture to be free of defects in workmanship and material under normal use and service. Gold Medal Products Co.'s obligation under this warranty is limited solely to repairing or replacing parts, f.o.b. Cincinnati, Ohio, which in its judgment are defective in workmanship or material and which are returned, freight prepaid, to its Cincinnati, Ohio factory or other designated point. Except for "Perishable Parts" on specific machines, the above warranty applies for a period of two (2) years from the date of original sale to the original purchaser of equipment when recommended operating instructions and maintenance procedures have been followed. These are packed with the machine. Parts warranty is two (2) years, labor is six (6) months.

THIS WARRANTY IS IN LIEU OF ALL OTHER WARRANTIES EXPRESSED OR IMPLIED, AND OF ALL OTHER OBLIGATIONS OR LIABILITIES ON OUR PART, INCLUDING THE IMPLIED WARRANTY OF MERCHANTABILITY. THERE ARE NO WARRANTIES WHICH EXTEND BEYOND THE DESCRIPTION ON THE FACE HEREOF. In no event shall Gold Medal Products Co. be liable for special, incidental or consequential damages. No claim under this warranty will be honored if the equipment covered has been misused, neglected, damaged in transit, or has been tampered with or changed in any way. No claim under this warranty shall be honored in the event that components in the unit at the time of the claim were not supplied or approved by Gold Medal Products Co. This warranty is effective only when electrical items have been properly attached to city utility lines only at proper voltages. This warranty is not transferable without the written consent of Gold Medal Products Co.

The term "Original Purchaser" as used in this warranty shall be deemed to mean that person, firm, association, or corporation who was billed by the GOLD MEDAL PRODUCTS CO., or their authorized distributor for the equipment.

THIS WARRANTY HAS NO EFFECT AND IS VOID UNLESS THE ORIGINAL PURCHASER FIRST CALLS GOLD MEDAL PRODUCTS CO. AT 1-800-543-0862 TO DISCUSS WITH OUR SERVICE REPRESENTATIVE THE EQUIPMENT PROBLEM, AND, IF NECESSARY, FOR INSTRUCTIONS CONCERNING THE REPAIR OR REPLACEMENT OF PARTS.

NOTE: This equipment is manufactured and sold for commercial use only.



GOLD MEDAL PRODUCTS CO.

10700 Medallion Drive, Cincinnati, Ohio 45241-4807 USA

gmpopcorn.com

Phone: (800) 543-0862 Fax: (800) 542-1496
(513) 769-7676 (513) 769-8500